

KW4A(S)型微動開關系列 Micro switch series

◆ 安全可靠的小型開關 Safe, reliable miniature switch

- 結構緊湊。具有微小觸點間隙，快速動作、高靈敏和微小動作行程的特點。
Nice appearance, tight configuration. Characteristic: small contact gap, quick action, high sensitivity and small operating travel.
- 長壽命，高可靠。
Long life, high reliability.
- 接線端子種類齊全
A variety of contact terminals
- 配備各種形式動臂
A variety of levers
- 廣泛應用於各種家用電器、電子設備、自動化設備、通訊設備、汽車電子、儀器儀表等領域。
Widely used in home appliance, electronic equipment, automatic machine, communication equipment, car electron, apparatus and instrument etc.

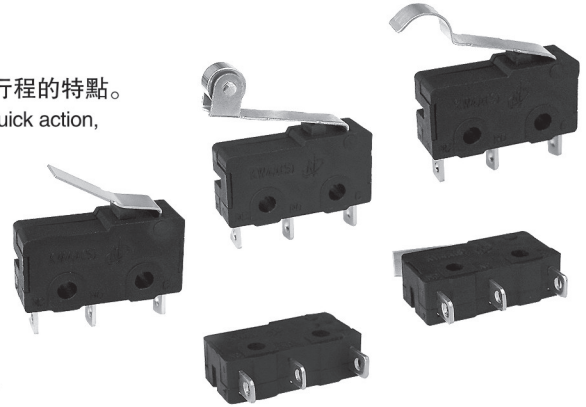

◆ 技術特性 Specifications

項目 Item		特性值 Value
工作速度 Operating speed		0.1mm ~ 1m/s (與驅動方式有關) (Related with actuator forms)
工作頻率 Operating frequency		機械 60次/min; 電氣 25次/min Mechanical 60 cycles/min; Electrical 25 cycles/min
絕緣電阻 Insulation resistance		≥ 100MΩ (500VDC)
接觸電阻 Contact resistance		動作力 > 0.5N: ≤ 30mΩ (見注) OF > 0.5N: ≤ 30mΩ (see note) 動作力 ≤ 0.5N: ≤ 50mΩ (見注) OF ≤ 0.5N: ≤ 50mΩ (see note)
耐電壓 Test voltage	同極不相接端子間 Between terminals of the same polarity	AC1000V, 50/60Hz, 1min
	帶電金屬零件與地(外殼)之間、接線端與不帶電金屬件之間 Between current-carrying metal parts and ground(case), and between each terminal and non-current-carrying metal parts.	AC1500V, 50/60Hz, 1min
抗振動 Vibration resistance		10 ~ 55Hz, 1.5mm雙振幅 Double amplitude
抗衝擊 Shock resistance		破壞: 動作力 > 0.5N: 1000m/s ² (約100G)max 動作力 ≤ 0.5N: 500m/s ² (約50G)max 故障: 動作力 > 0.5N: 300m/s ² (約30G)max 動作力 ≤ 0.5N: 200m/s ² (約20G)max Destruction: OF > 0.5N: 1000m/s ² (approx. 100G)max OF ≤ 0.5N: 500m/s ² (approx. 50G)max Malfunction: OF > 0.5N: 300m/s ² (approx. 30G)max OF ≤ 0.5N: 200m/s ² (approx. 20G)max
壽命 Life		機械 ≥ 1,000,000次; Mechanical ≥ 1,000,000 cycles 電氣 ≥ 10,000次; Electrical ≥ 10,000 cycles 電氣 ≥ 50,000次(TUV, CQC); Electrical ≥ 50,000 cycles(TUV, CQC)
質量 Weight		約1.6g(無動臂型) Approx. 1.6g(No lever)
安全認證 Safety approvals		UL、CUL、VDE、TUV、SEMKO、ENEC、DEMKO、CE、EK、CQC

注：指無動臂時按鈕上的動作力。 Note: Refers to the operating force of no lever.



◆ 型號規格命名及含義 Model number legend and meanings

KW4A(S) □-□□□□□□ - (□)
 1 2 3 4 5 6 7 8

1 溫度等級 Degrees of temperature	無標記 No mark: 10T85 T125	5 端子類型 Terminal type	F: 焊接端子 Solder terminal P: PCB端子 PCB terminal L: 左側面PCB端子 Left side PCB terminal R: 右側面PCB端子 Right side PCB terminal T: 110快接端子 Quick-connect terminal Y: 非標準端子 Not standard terminal
2 額定值 Ratings	無標記 No mark: 5GPA125/250VAC 5A250VAC 5(2)A125/250VAC 1/4hp250VAC, 4A30VDC KW4A(S)-A: 10GPA125/250VAC 10A250VAC 10(3)A125/250VAC 1/2hp250VAC, 4A30VDC KW4A(S)-B: 3GPA125/250VAC 3A250VAC 3(1)A125/250VAC KW4A(S)-C: 1GPA125/250VAC, 1A250VAC 1(0.5)A125/250VAC KW4A(S)-F: 0.1GPA125/250VAC 0.1A250VAC 0.1(0.05)A125/250VAC	6 動作力(max) operating force	050: 0.5N 100: 1N 150: 1.5N 200: 2N 300: 3N 注: 若是非標準動作力, 用此動作力上限值表示。 Note: if it is not standard operating force, indicate with the upper limit.
3 接觸形式 Circuit	Z: 轉換式 SPDT T: 常開(按通)式 SPST-NO D: 常閉(按斷)式 SPST-NC (見說明圖 See illustration)	7 按鈕規格 Plunger specs	無標記 No mark: 標準按鈕 Standard plunger A: 短按鈕 Short plunger B: 長按鈕 Long plunger D: 异形按鈕 Abnormity plunger (見說明圖 see illustration) 注: 若採用本表中未列入的非標準按鈕, 則用此新增按鈕的規格代號(本公司確認)表示。 Note: if adopt other not standard plunger, then indicate with the new spec (confirmed by our company).
4 驅動形式 Actuator forms	0: 無動臂 No lever 1: 短動臂 Short lever 2: 長動臂 Long lever 3: 中動臂 Middle lever 5: 滾輪臂 Roller 6: 弧形動臂 Arc lever □-非標準動臂 Not standard lever 注: □表示非標準動臂的代號, 詳見動臂外形尺寸圖。 Note: □Indicate not standard lever, details see outline measurement drawings.	8 附加規格編號 適用於: Additional spec numbers, apply to:	1) 當開關使用了非標準零件如非標準端子時; When used not standard parts such as not stand ard terminal; 2) 當顧客有特殊動作特性值或其它要求時。 When customer has particular operating value or other requirements. 附加規格編號用阿拉伯數字表示, 在沒有附加規格編號時, 該位置空缺。 Additional specs number shows by Arabic numerals. If there is no additional numbers, the place is vacant.

◆ 接觸形式說明圖 Circuit illustration

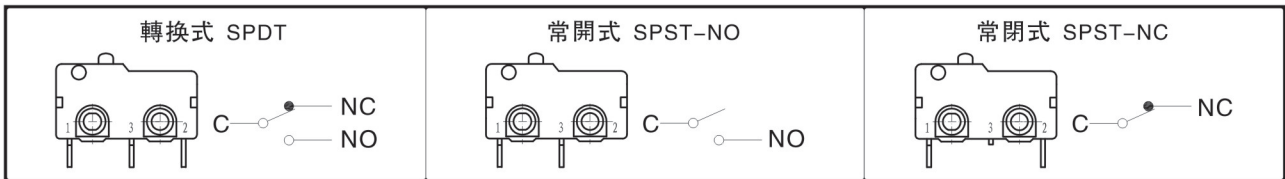

◆ 按鈕規格說明圖 Plunger spec illustration

按鈕標記 Mark on plunger	無標記 No mark	A	D
按鈕尺寸 Plunger dimension			

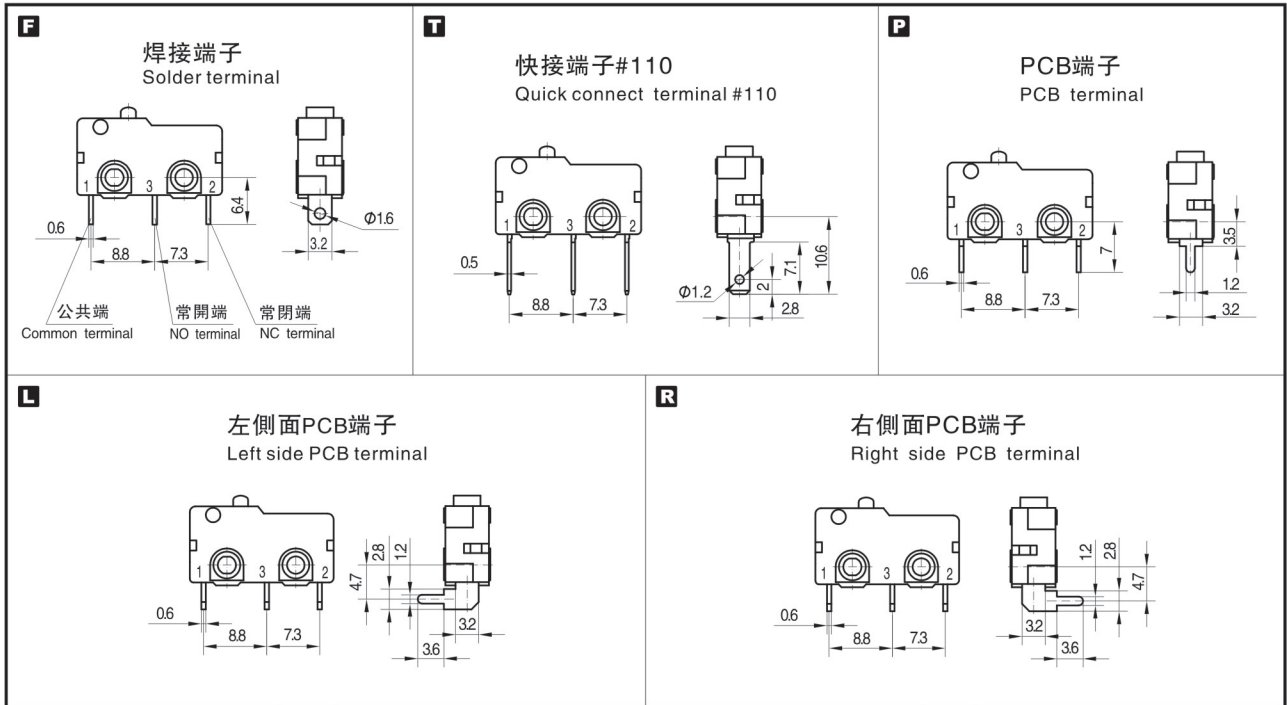
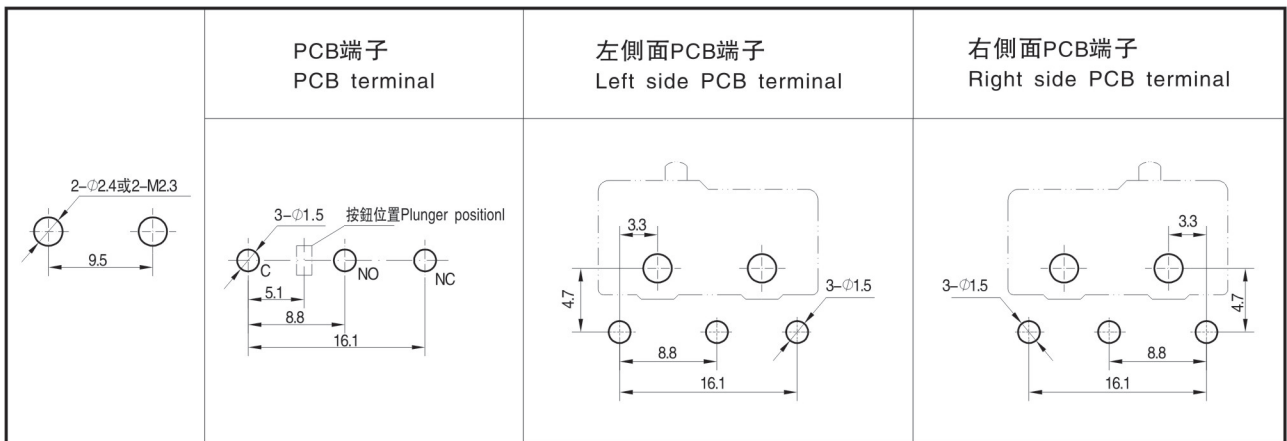
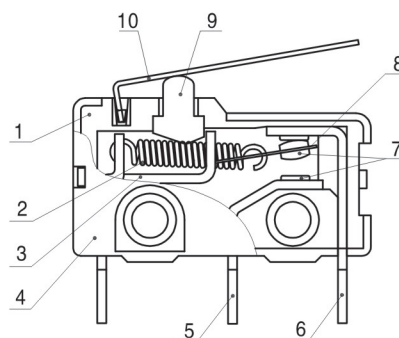
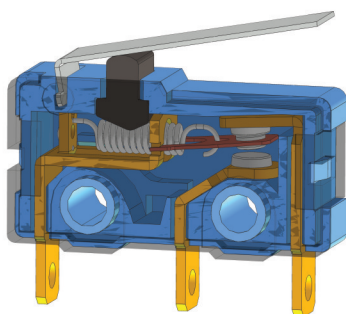
◆ 接線端尺寸 Terminal dimensions

◆ 安裝孔尺寸 Mounting hole dimension

◆ 內部構造圖 Internal configuration drawing

- | | |
|-----------|--------------|
| 1:基座 | Case |
| 2:拉簧 | Pull spring |
| 3:支架 | Support |
| 4:蓋 | Cover |
| 5:常開端子 | NO terminal |
| 6:常閉端子 | NC terminal |
| 7:電觸點 | Contact |
| 8:可動片 | Moving piece |
| 9:開關子(按鈕) | Plunger |
| 10:動臂 | Lever |

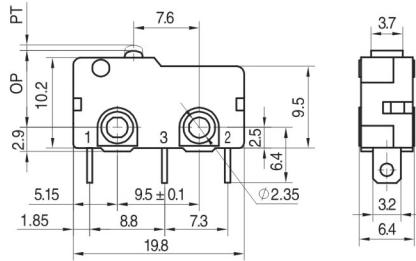
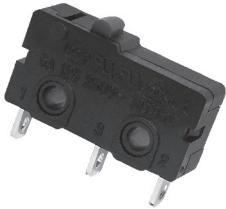

◆ 外形尺寸和動作特性 Dimensions and operating characteristics

KW4A(S)-Z0F100
KW4A(S)-Z0F150
KW4A(S)-Z0F200
KW4A(S)-Z0F300



型號 Model	KW4A(S)-Z0F100	KW4A(S)-Z0F150	KW4A(S)-Z0F200	KW4A(S)-Z0F300
OF Max(N)	1.00	1.50	2.00	3.00
RF Min(N)	0.15	0.30	0.50	0.70
PT Max(mm)	0.8			
OT Min(mm)	0.5			
MD Max(mm)	0.2			
OP(mm)	8.6±0.4			

KW4A(S)-Z1F100
KW4A(S)-Z1F150
KW4A(S)-Z1F200
KW4A(S)-Z1F300

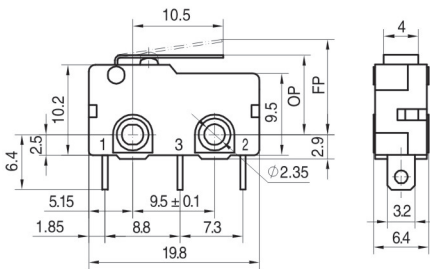

型號 Model	KW4A(S)-Z1F100	KW4A(S)-Z1F150	KW4A(S)-Z1F200	KW4A(S)-Z1F300
OF Max(N)	0.40	0.50	0.60	0.80
RF Min(N)	0.10	0.15	0.20	0.30
OT Min(mm)	1.0			
MD Max(mm)	0.6			
FP Max(mm)	11.5			
OP(mm)	9±0.8			

KW4A(S)-Z3F100
KW4A(S)-Z3F150
KW4A(S)-Z3F200
KW4A(S)-Z3F300

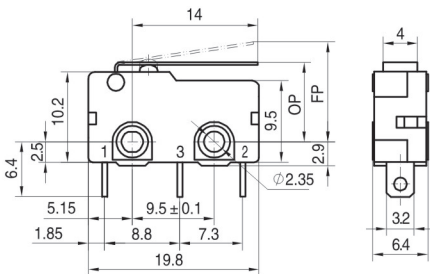
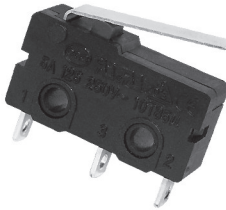

型號 Model	KW4A(S)-Z3F100	KW4A(S)-Z3F150	KW4A(S)-Z3F200	KW4A(S)-Z3F300
OF Max(N)	0.25	0.40	0.50	0.80
RF Min(N)	0.04	0.08	0.15	0.20
OT Min(mm)	0.8			
MD Max(mm)	0.8			
FP Max(mm)	12.5			
OP(mm)	8.9±1			

KW4A(S)-Z2F100
KW4A(S)-Z2F150
KW4A(S)-Z2F200
KW4A(S)-Z2F300

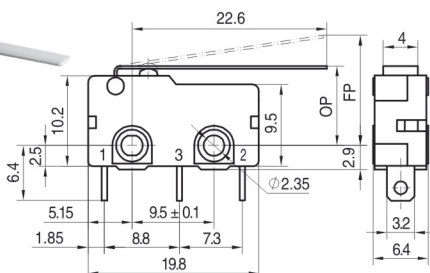

型號 Model	KW4A(S)-Z2F100	KW4A(S)-Z2F150	KW4A(S)-Z2F200	KW4A(S)-Z2F300
OF Max(N)	0.20	0.30	0.35	0.45
RF Min(N)	0.03	0.08	0.10	0.15
OT Min(mm)	1.6			
MD Max(mm)	1.5			
FP Max(mm)	15.0			
OP(mm)	9±1.5			

◆ 外形尺寸和動作特性 Dimensions and operating characteristics

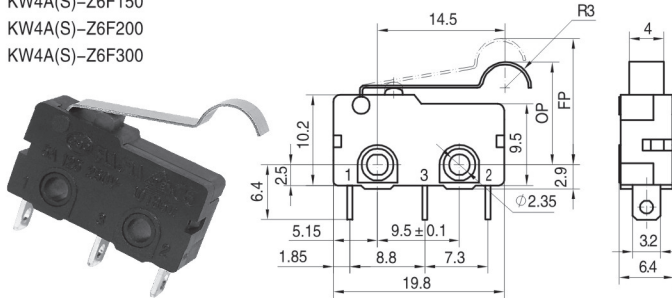
 KW4A(S)-Z6F100
 KW4A(S)-Z6F150
 KW4A(S)-Z6F200
 KW4A(S)-Z6F300

型號 Model	KW4A(S)-Z6F100	KW4A(S)-Z6F150	KW4A(S)-Z6F200	KW4A(S)-Z6F300
OF Max(N)	0.25	0.40	0.50	0.80
RF Min(N)	0.04	0.08	0.15	0.20
OT Min(mm)	1.5			
MD Max(mm)	0.8			
FP Max(mm)	16.5			
OP(mm)	13.4 ± 1			

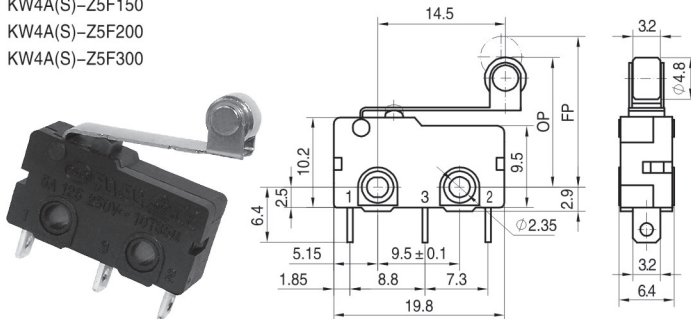
 KW4A(S)-Z5F100
 KW4A(S)-Z5F150
 KW4A(S)-Z5F200
 KW4A(S)-Z5F300

型號 Model	KW4A(S)-Z5F100	KW4A(S)-Z5F150	KW4A(S)-Z5F200	KW4A(S)-Z5F300
OF Max(N)	0.25	0.40	0.50	0.80
RF Min(N)	0.04	0.08	0.15	0.20
OT Min(mm)	1.2			
MD Max(mm)	0.9			
FP Max(mm)	19.0			
OP(mm)	15.2 ± 1			

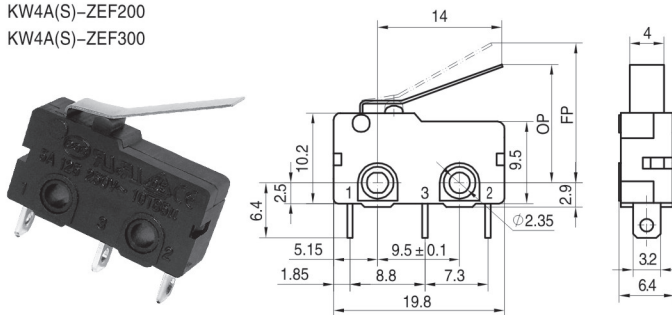
 KW4A(S)-ZEF100
 KW4A(S)-ZEF150
 KW4A(S)-ZEF200
 KW4A(S)-ZEF300

型號 Model	KW4A(S)-ZEF100	KW4A(S)-ZEF150	KW4A(S)-ZEF200	KW4A(S)-ZEF300
OF Max(N)	0.25	0.40	0.50	0.80
RF Min(N)	0.04	0.08	0.15	0.20
OT Min(mm)	1.2			
MD Max(mm)	0.8			
FP Max(mm)	16.5			
OP(mm)	13 ± 1			

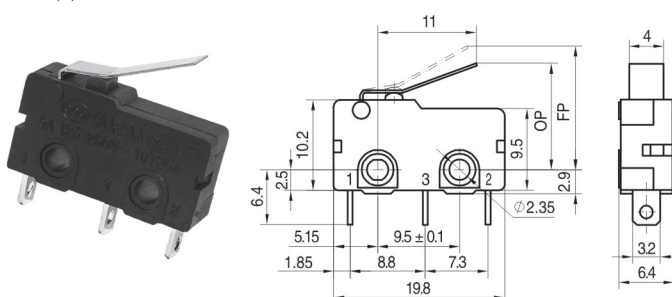
 KW4A(S)-ZQF100
 KW4A(S)-ZQF150
 KW4A(S)-ZQF200
 KW4A(S)-ZQF300

型號 Model	KW4A(S)-ZQF100	KW4A(S)-ZQF150	KW4A(S)-ZQF200	KW4A(S)-ZQF300
OF Max(N)	0.32	0.50	0.65	1.00
RF Min(N)	0.04	0.08	0.15	0.20
OT Min(mm)	1.0			
MD Max(mm)	0.8			
FP Max(mm)	15.0			
OP(mm)	12.2 ± 0.8			



◆ 外形尺寸和動作特性 Dimensions and operating characteristics

KW4A(S)-Z6BF100
 KW4A(S)-Z6BF150
 KW4A(S)-Z6BF200
 KW4A(S)-Z6BF300

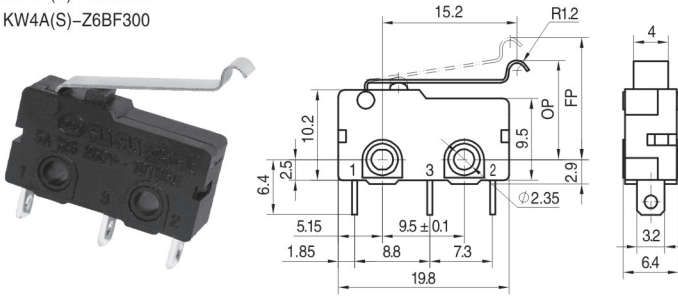

型號 Model	KW4A(S)-Z6BF100	KW4A(S)-Z6BF150	KW4A(S)-Z6BF200	KW4A(S)-Z6BF300
OF Max(N)	0.25	0.40	0.50	0.80
RF Min(N)	0.04	0.08	0.15	0.20
OT Min(mm)	1.2			
MD Max(mm)	0.8			
FP Max(mm)	15.5			
OP(mm)	12 ± 1.2			

◆ 可供選擇的非標準動臂代號和外形特征尺寸 Not standard levers for choose and outline characteristic dimension

動臂代號 Lever code	外形特征尺寸 Outline characteristic dimensions	動臂代號 Lever code	外形特征尺寸 Outline characteristic dimensions	動臂代號 Lever code	外形特征尺寸 Outline characteristic dimensions
3A		C		K	
N		G		Q1	
J		F1		S1	
J1		6A		5A	
J2		6C			

◆ **請正確使用** Please use it correctly

【共通注意事項】請參閱相關頁。

【Common points for attention】please refer to related pages

■ 關於和端子的連接 Concerning the connection with terminals

(1) 將導線焊接到端子上時，請先將導線穿過端子孔後再進行焊接。

When jointing the wire to the terminal, please thread through the wire to the hole of the terminal first.

(2) 烙鐵的容量應為60W以下，焊接時間在3s之內。若操作溫度過高或時間過長，可能導致開關特性劣化。

The iron capacity should be below 60W, joint time within 3s. If operate temperature is too high or time is too long, switch characteristic may be worsen

(3) 請採用手工焊接。因為如果採用焊槽焊接，焊錫可能進入開關內部而導致接觸不良。

Please joint with hands. If joint with wave soldering, soldering tin may come inside the switch, then bad contact will happen.

(4) 對於快接式端子，插套插入插片時，應避免在端子的橫向加力，以免引起端子變形和外殼破損。

Regarding the quick connect terminal, when insert slipcover into the insert piece, please do not exert transverse press to the terminal, in order to avoid terminal distort and cover breakage.

■ 關於絕緣距離 Concerning insulation distance

根據IEC 61058-1/EN 61058-1/GB 15092.1之規定，本開關的最小絕緣層厚度為1.1mm，端子和安裝板之間的最小空間距離為1.6mm。如果無法確保零部件所要求的絕緣距離，請使用絕緣護罩或隔板來保證絕緣距離。

According to IEC 61058-1/EN 61058-1/GB 15092.1, the least thickness insulation layer should be 1.1mm, the smallest space distance between the terminal and install board is 1.6mm. If the parts insulation distance cannot be guaranteed please use insulate cover or the guard board to guarantee the insulation distance.

■ 關於安裝 Concerning installation

(1) 開關的安裝、拆卸和配線作業以及維護檢查時，請務必斷開電源，否則會引起觸電和燒毀。

Please turn off the power when installing, disassembling, wiring work and maintenance check, otherwise, electric shock and burn will happen.

(2) 安裝時，使用2個M2.3螺釘，用平墊圈、彈簧墊圈等緊固，並請使用0.23~0.26N·m的緊固轉矩。

When installing, please use 2 M2.3 screws, then tight it with flat washer, spring washer, and also tight with 0.23~0.26N·m torque.

(3) 開關請安裝在平面上。如果安裝面凹凸不平，可能導致開關歪斜、動作失常和外殼破損。

Please install switch on flat surface. If it is installed in uneven surface, switch deflection, malfunction and cover breakage will happen.

■ 關於微小負載電路中的使用 Concerning use in small load circuit

如果在開關微小負載電路中使用一般負載用開關，可能會引起接觸不良。

Use general load switch in small load circuit, bad contact maybe happen.

請參考下圖在使用區域的範圍內使用開關，並根據需要插入觸點保護電路。

Please refer to the chart below, use switch within using region, and insert contact protection circuit according to the needs.

